

LED VAPOR TIGHT LIGHT

Specification sheet

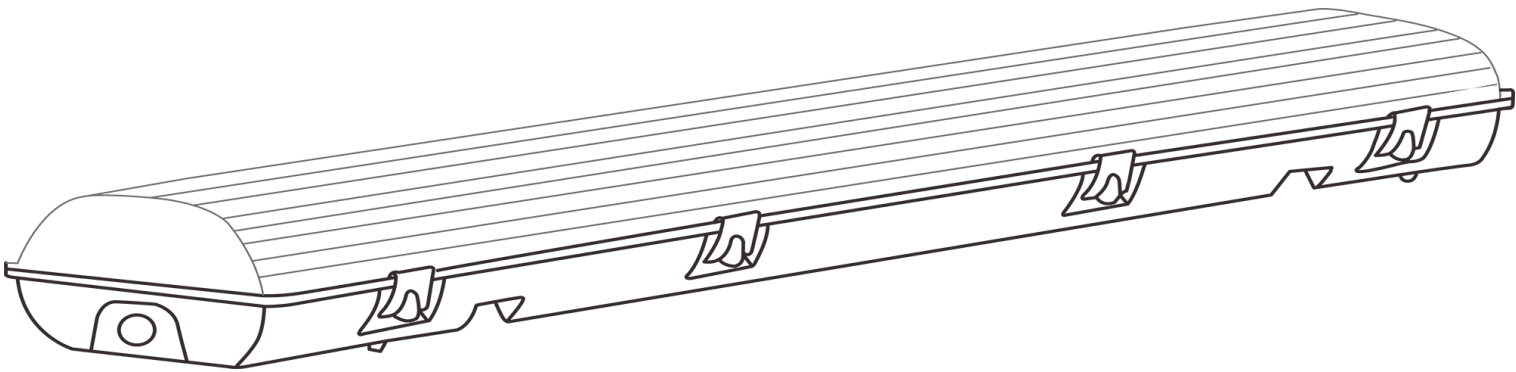

PRODUCT DESCRIPTION

Fulton Tri-proof light is usually used in environment which require water-proof ,dust-proof ,corrosion-proof lighting ,such as shopping mall , warehouse and other indoor places . The lamp features with smooth surface , no dust deposition ,can be ceiling mounted or suspending mounted.

FEATURES:

- Water-proof design without adhesive, so there is no water leakage caused by adhesive aging , Convenient to disassemble;
- Light panel and PSU adopt modular design, connected via terminals, easy and convenient to Maintain, no need of soldering;
- Energy saving and eco-friendly, no IR or UV, no mercury contamination , RoHS compliant;
- High transmittance PC cover transmit soft light + small power LEDs, high light efficiency, uniform Light; No dark spot;
- High efficient heat dissipation, LEDs and power supply with low temperature rise, high stability under Continuous working;
- Can be switched on/off frequently, good color rendering performance. Compact appearance, novel design style, easy to install and transport;

APPLICATIONS:

Car Washes/Food processing
Gas Station/Laboratories
Industrial Facilities
Refrigeration/Freezers
Parking Garage/Utility
Warehouse/Supermarket



ORDERING: (first “xx” can be 27,30,35,40,45,50,57; third “x” can be S or D; last “xx” can be RA or IS) (The lumens are tested with frosted lens) GWIT test 850 °C

Item	Watts	Diffusion Efficacy	Frost Efficacy	CRI	PF	Voltage	Dimension(L*W*H):Inch		
FLT-TPOXX-25L6XXX	25 W	130lm/w	120lm/w	>80	>0.92	AC100-277V	22 3/25	6 3/10	3 9/10
FLT-TPOXX-40L12XXX	40W	130lm/w	120lm/w	>80	>0.92	AC100-277V	50 3/10	6 3/10	3 9/10
FLT-TPOXX-60L12XXX	60 W	130lm/w	120lm/w	>80	>0.92	AC100-277V	50 3/10	6 3/10	3 9/10
FLT-TPOXX-75L12XXX	75 W	130lm/w	120lm/w	>80	>0.92	AC100-277V	50 3/10	6 3/10	3 9/10

*Please contact your Fulton representative to order products that don't have order codes listed here or any info required
*Due to continuing product improvements, Fulton Lighting reserves the right to change the specifications without notice.

LED Tri-proof light (Vapor Tight Light)

Photometric Diagram

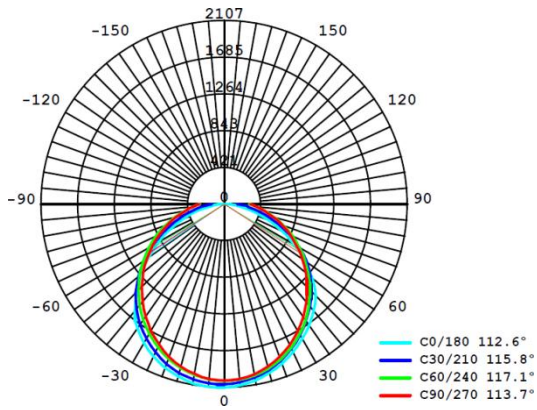

AVERAGE BEAM ANGLE(50%)114.8

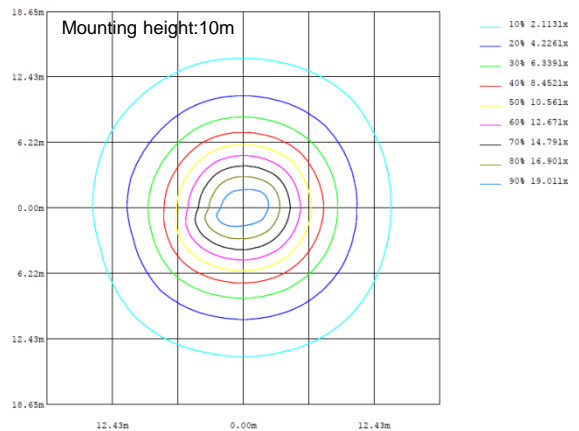
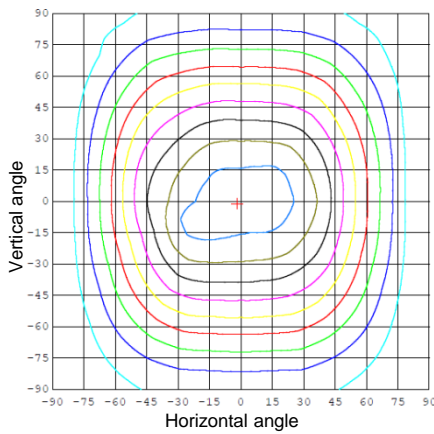
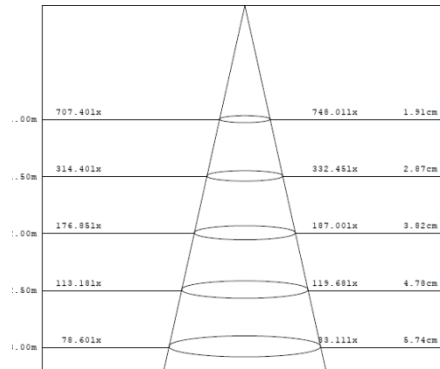

Lifetime +Sustainability

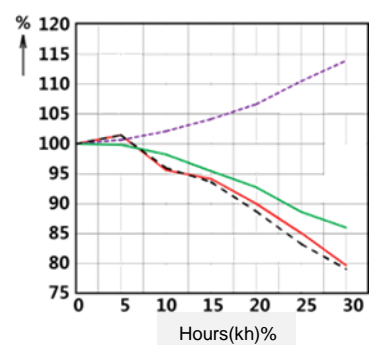
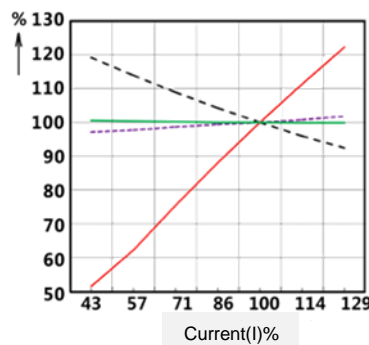
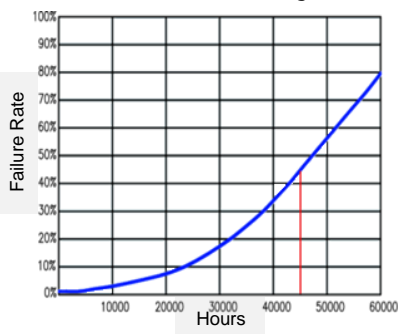

— Luminous Efficacy - - Rated Luminous Flux - - - CCT - - CRI



PRODUCT DESCRIPTION

Fulton Tri-proof light is usually used in environment which require water-proof ,dust-proof ,corrosion-proof lighting ,such as shopping mall , warehouse and other indoor places . The lamp features with smooth surface , no dust deposition ,can be ceiling mounted or suspending mounted.

FEATURES:

- Water-proof design without adhesive, so there is no water leakage caused by adhesive aging , Convenient to disassemble;
- Light panel and PSU adopt modular design, connected via terminals, easy and convenient to Maintain, no need of soldering;
- Energy saving and eco-friendly, no IR or UV, no mercury contamination , RoHS compliant;
- High transmittance PC cover transmit soft light + small power LEDs, high light efficiency, uniform Light; No dark spot;
- High efficient heat dissipation, LEDs and power supply with low temperature rise, high stability under Continuous working;
- Can be switched on/off frequently, good color rendering performance. Compact appearance, novel design style, easy to install and transport;

APPLICATIONS:

- Car Washes/Food processing
- Gas Station/Laboratories
- Industrial Facilities
- Refrigeration/Freezers
- Parking Garage/Utility
- Warehouse/Supermarket



ORDERING: (first “xx” can be 27,30,35,40,45,50,57; third “x” can be S or D; last “xx” can be RA or IS) (The lumens are tested with frosted lens) GWIT test 850°C

Item	Watts	Diffusion Efficacy	Frost Efficacy	CRI	PF	Voltage	Dimension(L*W*H):Inch		
FLT-TPOXX-20L6XXX	20 W	130lm/w	120lm/w	>80	>0.92	AC100-277V	23 7/30	3 3/4	2 19/20
FLT-TPOXX-40L12XXX	40 W	130lm/w	120lm/w	>80	>0.92	AC100-277V	46 17/20	3 3/4	2 19/20
FLT-TPOXX-50L12XXX	50 W	130lm/w	120lm/w	>80	>0.92	AC100-277V	46 17/20	3 3/4	2 19/20

*Please contact your Fulton representative to order products that don't have order codes listed here or any info required
 *Due to continuing product improvements, Fulton Lighting reserves the right to change the specifications without notice.

LED Tri-proof light (Vapor Tight Light)

Photometric Diagram

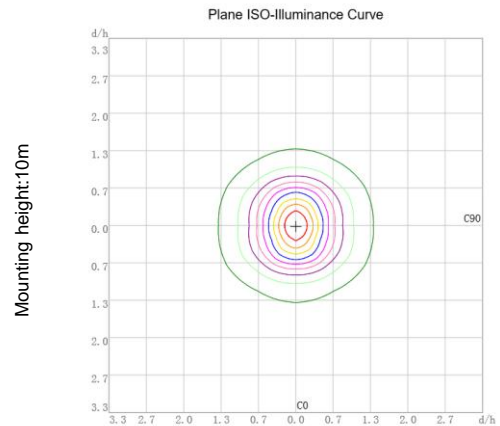
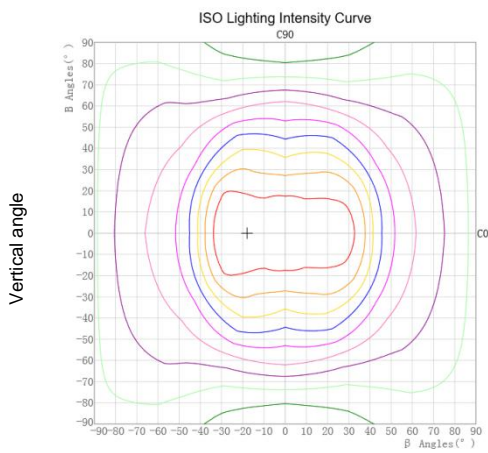
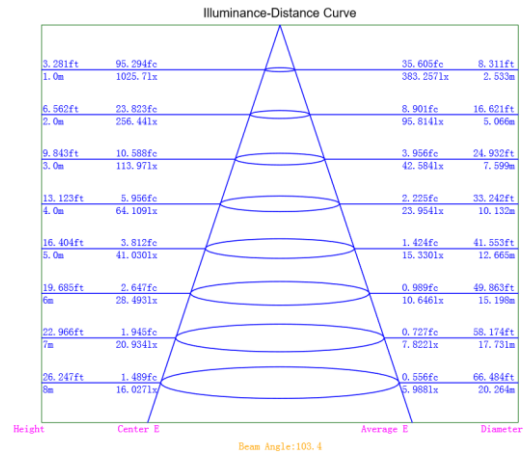
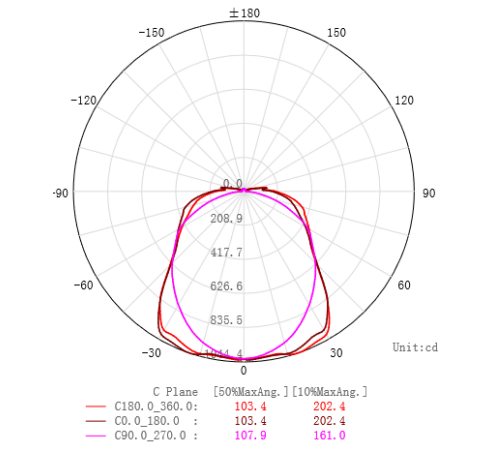

Lifetime +Sustainability

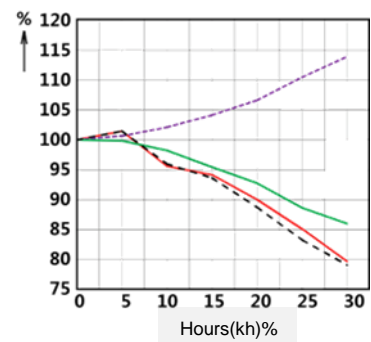
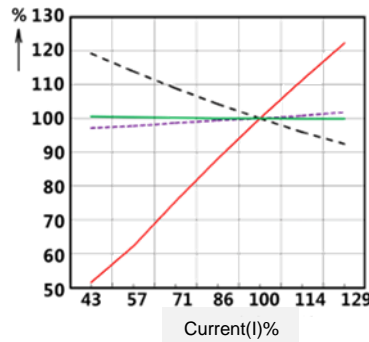
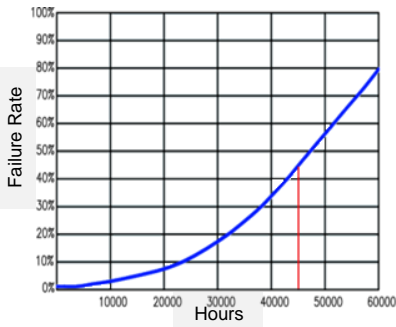

— Luminous Efficacy - - Rated Luminous Flux - - - CCT - - - CRI



LED Tri-proof light (Vapor Tight Light)

Wiring diagram

Cautions:

Before installation, be sure to cut off electricity to avoid electric shock.

This is one end wiring LED Tri-proof light with build-in driver. Powered by the voltage labeled on the LED Tri-proof light , no need to add other drivers.

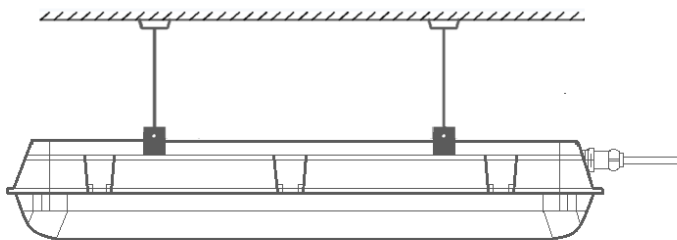

A hanging

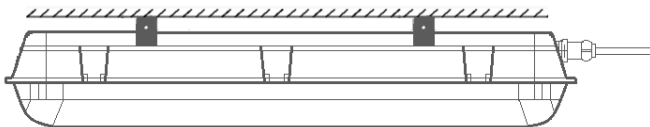

B Ceiling type

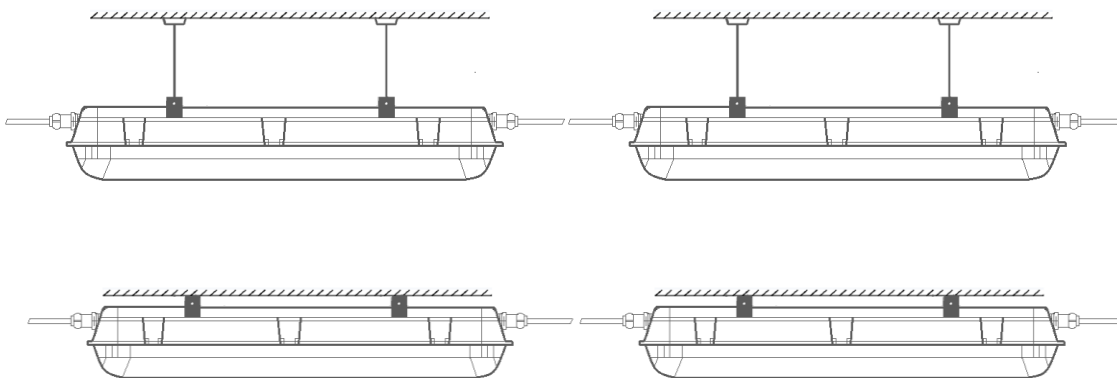

LED Tri-proof light (Vapor Tight Light)

Package Information

Part No.	Specification (Foot)	Q'ty (PCS)	Packing Volume weight (Kg)	Packing size (mm) LXWXH	20GP	40HC
FLT-TPO-L6-P	2	10	17.5	710*515*346		
FLT-TPO-L12-P	4	10	17.5	1310*515*346		
FLT-TPO-L6	2	20	17.5	680*420*300		
FLT-TPO-L12	4	10	17.5	1280*420*160		

